

Clamp-in Valves

These valves may be bent to the desired configuration in accordance with tubeless valve dimension chart in section nine (9) of the Tire and Rim Book, made to order.

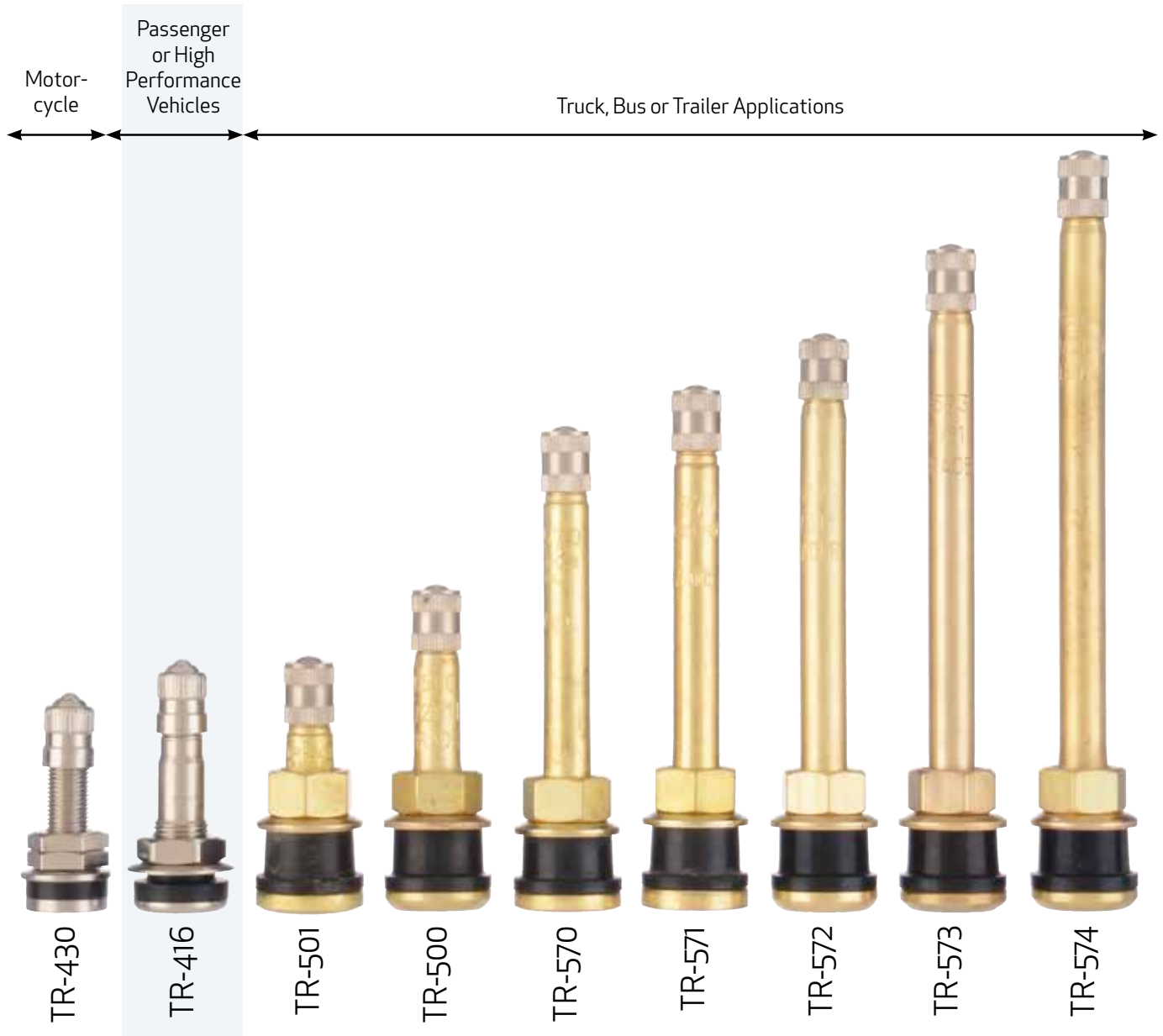

Due to the variety of operating conditions or applications, the customer is responsible to perform their own testing to insure performance, safety and warning requirements for the intended application.



SCHRADER-USA 205 FRAZIER ROAD ▶ ALTAVISTA, VA 24517

CUSTOMER SUPPORT LINE // 1.800.288.1804 x8817 ▶ SCHRADERINTERNATIONAL.COM

07132017

Clamp-in Valves

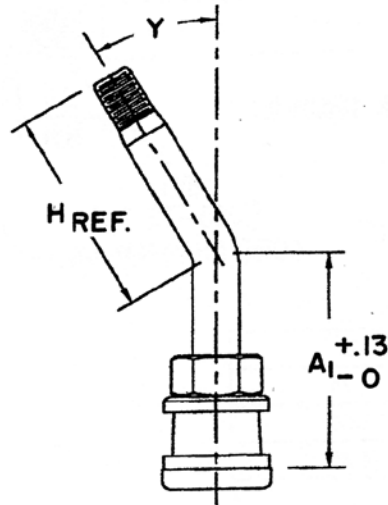

Tool Setting	A	B	C	D	E	F	G	H	I	J	K	L	M	N	O	P	Q
Angle - Y	4°	11°	16°	21°	26°	31°	36°	41°	46°	51°	56°	61°	66°	71°	76°	81°	86°

TOOL SETTING TO PRODUCE LENGTHS A AND H						
Tool Setting	Length H	LENGTHS A, +.13 -0				
		TR 570	TR 571	TR 572	TR 573	TR 574
12	1.50	1.63	1.88	2.25	2.88	3.50
13	1.63	1.50	1.75	2.13	2.75	3.38
14	1.75	1.38	1.63	2.00	2.63	3.25
15	1.88	1.25	1.50	1.88	2.50	3.13
16	2.00	1.13	1.38	1.75	2.38	3.00
17	2.13	1.00	1.25	1.63	2.25	2.88
18	2.25		1.13	1.50	2.13	2.75
19	2.38		1.00	1.38	2.00	2.63
20	2.50		*0.88	1.25	1.88	2.50
21	2.63			1.13	1.75	2.38
22	2.75			1.00	1.63	2.25
23	2.88			*0.88	1.50	2.13
24	3.00				1.38	2.00
25	3.13				1.25	1.88
26	3.25				1.13	1.75
27	3.38				1.00	1.63
28	3.50				*0.88	1.50
29	3.50					1.38
30	3.75					1.25
31	3.75					1.13
32	4.00					1.00

*At A = 0.88, the maximum bend angle is 26°

NOTE: Valve Designation:

TR Valve No. - Tool Setting

Example: TR 570-C12



SCHRADER-USA 205 FRAZIER ROAD ▶ ALTAVISTA, VA 24517

CUSTOMER SUPPORT LINE // 1.800.288.1804 x8817 ▶▶ SCHRADERINTERNATIONAL.COM